

# GAZELLE<sup>®</sup>

## **GH2000** Heat Gun User Manual



## General power tool safety warnings

 **WARNING! Read and understand all instructions.** *Failure to follow all instructions listed below may result in electric shock, fire and/or serious personal injury.*

**Save all warnings and instructions for future reference.**

*The term "power tool" in the warnings refers to your mains-operated (corded) power tool or battery-operated (cordless) power tool.*

### 1) Work Area Safety

- a) **Keep work area clean and well lit.** *Cluttered or dark areas invite accidents.*
- b) **Do not operate power tools in explosive atmospheres, such as in the presence of flammable liquids, gases, or dust.** *Power tools create sparks which may ignite the dust or fumes.*
- c) **Keep children and bystanders away while operating a power tool.** *Distractions can cause you to lose control.*

### 2) Electrical Safety

- a) **Power tool plugs must match the outlet. Never modify the plug in anyway. Do not use any adapter plugs with earthed (grounded) power tools.** *Unmodified plugs and matching outlets will reduce risk of electric shock.*
- b) **Avoid body contact with earthed or grounded surfaces, such as pipes, radiators, ranges and refrigerators.** *There is an increased risk of electric shock if your body is earthed or grounded.*
- c) **Do not expose power tools to rain or wet conditions.** *Water entering a power tool will increase the risk of electric shock.*
- d) **Do not abuse the cord. Never use the cord for carrying, pulling or unplugging the power tool. Keep cord away from heat, oil, sharp edges or moving parts.** *Damaged or entangled cords increase the risk of electric shock.*
- e) **When operating a power tool outdoors, use an extension cord suitable for outdoor use.** *Use of a cord suitable for outdoor use reduces the risk of electric shock.*
- f) **If operating a power in a damp location is unavoidable, use a residual current device (RCD) protected supply.** *Use of an RCD reduces the risk of electric shock.*

*NOTE: The term "residual current device (RCD)" may be replaced by the term "ground fault circuit interrupter (GFCI)" or "earth leakage circuit breaker (ELCB)".*

### 3) Personal Safety

- a) **Stay alert, watch what you are doing and**

**use common sense when operating a power tool. Do not use a power tool while you are tired or under the influence of drugs, alcohol, or medication.** *A moment of inattention while operating power tools may result in serious personal injury.*

- b) **Use personal protective equipment. Always wear eye protection.** *Protective equipment such as dust mask, non-skid safety shoes, hard hat, or hearing protection used for appropriate conditions will reduce personal injuries.*
- c) **Prevent unintentional starting. Ensure the switch is in the off-position before connecting to power source and /or battery pack, picking up or carrying the tool.** *Carrying power tools with your finger on the switch or energising power tools that have the switch on invites accidents.*
- d) **Remove any adjusting key or wrench before turning the tool on.** *A wrench or a key left attached to a rotating part of the power tool may result in personal injury.*
- e) **Do not overreach. Keep proper footing and balance at all times.** *This enables better control of the power tool in unexpected situations.*
- f) **Dress properly. Do not wear loose clothing or jewellery. Keep your hair, clothing, and gloves away from moving parts.** *Loose clothes, jewellery or long hair can be caught in moving parts.*
- g) **If devices are provided for the connection of dust extraction and collection facilities, ensure these are connected and properly used.** *Use of dust collection can reduce dust-related hazards.*
- h) **During the operation, do not take it lightly and ignore the safety guidelines because of frequent use of the tool.** *Any careless motion may cause serious injuries.*

### 4) Power Tool Use and Care

- a) **Do not force the power tool. Use the correct power tool for your application.** *The correct power tool will do the job better and safer at the rate for which it was designed.*
- b) **Do not use tool if switch does not turn it on or off.** *Any power tool that cannot be controlled with the switch is dangerous and must be repaired.*
- c) **Disconnect the plug from the power source and/or the battery pack from the power tool before making any adjustments, changing accessories, or storing power tools.** *Such preventive safety measures reduce the risk of starting the power tool accidentally.*
- d) **Store idle power tools out of the reach of children and do not allow persons unfamiliar with the power tool or these instructions to operate the power tool.** *Power tools are dangerous in the hands of untrained users.*
- e) **Maintain power tools. Check for misalignment**

or binding of moving parts, breakage of parts and any other condition that may affect the power tool's operation. If damaged, have the power tool repaired before use. *Many accidents are caused by poorly maintained power tools.*

- f) **Keep cutting tools sharp and clean.** *Properly maintained cutting tools with sharp cutting edges are less likely to bind and are easier to control.*
  - g) **Use the power tool, accessories and tool bits etc. in accordance with these instructions, taking into account the working conditions and the work to be performed.** *Use of the power tool for operations different from those intended could result in a hazardous situation.*
  - h) **Keep the handle and grip surface dry, clean and free of grease.** *In the case of accidents, the slippery handle cannot guarantee the safety and control of the tool.*
- 5) **Service**
- a) **Have your power tool serviced by a qualified repair person using only identical replacement parts.** *This will ensure that the safety of the power tool is maintained.*

## ADDITIONAL SAFETY RULES

1. **Make sure the switch is in the off position before the tool is powered on.**
2. **Follow the voltage indicated on the tool nameplate to receive the power supply.**
3. **Tools up to a maximum temperature of 550°C (DQB02-1600, AQB02-1600, QQB02-1600), be sure to wear protective gloves and goggles.**
4. **Do not use this tool to dry animals, clothing or hair.**
5. **This tool should not be used as an electric hair dryer.**
6. **Use this tool in well-ventilated place.**
7. **Heat emitted by this tool during use may affect flammable substances beyond a distance.**
8. **When working with plastics, paints, lacquers**

and similar materials, combustible and poisonous gases can occur. Do not work in the vicinity of easily combustible gases or materials.

9. **Do not use the hot nozzle in the same place for a long time.**
10. **Improper use of tools can cause a fire.**
11. **When the tool starts, do not leave it unused.**
12. **Always hold the tool tightly when using it at high places.**
13. **Do not place the tool until it has stopped running**
14. **Do not block or cover the hot air outlet of the tool.**
15. **Do not touch the nozzle when the tool is in use or just after use.**
16. **Do not use this tool in rain or wet places.**
17. **Place the wires on the back end of the tool while you work.**
18. **Store the tools after they are cooled completely.** *Hot blowpipes can cause injury.*
19. **Do not allow children to operate this tool.**
20. **Warning! When working, the hot nozzle is at least 16mm away from the workpiece to ensure air flow.**
21. **Do not use tools with damaged cords.** *If the cord is damaged during work, it is strictly prohibited to touch the damaged cord and pull out the plug immediately. A damaged power cord increases the risk of electric shock for users.*

## Symbol



WARNING



To reduce the risk of injury, user must read instruction manual



Class II tool

---

## TECHNICAL DATA

### Intended Use

1. Heat up paint or coating for easily to be removed from the surface of metal or wood.

Caution: Be careful not to overheat the metal or inflame the wood.

Wear a dust respirator mask and keep the work area well ventilated as harmful gas may be produced during operation.

**WARNING!** Do not operate this tool while using thinner, pine oil or paint remover.

2. Remove sticky matter or decoration.
3. Remove rusty or too tight nut or metal screw, which are not made by plastic or fiber.
4. Unfreeze the frozen door lock and pipe (not plastic one).
5. Heat-shrink of PVC packing film and insulating tubing.
6. Shrink of polyethylene or equivalent for joint of metal pieces.
7. Soften weldment.
8. Dry damped wood before assembling or processing.

Model		GH2000	
Rated Power Input	W	2000	
Temperature	Low	°C	50-480
	High	°C	50-600
Air Flow	Low Temperature	L/min	210-250
	High Temperature	L/min	340-380
Net Weight	kg	0.6	

※Due to the continuing program of research and development, the specifications herein are subject to change without prior notice.

## INSTRUCTIONS FOR OPERATION

### Switch Operation

This tool has a two-gear adjustment function of wind speed.

When the tool's switch button is placed on OFF, the tool closes.

When the tool's switch button is placed on LOW, the tool is switched on to low speed.

When the tool's switch button is placed on HIGH, the tool is switched on to high speed.

**CAUTION: Before plugging in the tool, always check to see that the switch actuates properly.**

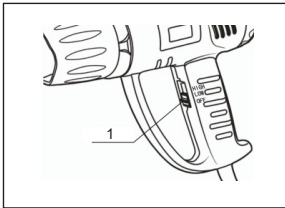

1.Switch Button

### Adjusting the Temperature

The working temperature can be adjusted.

To adjust the temperature, face to the adjusting knob after switching on the tool. Turn the adjusting knob clockwise to increase the temperature and counterclockwise to decrease the temperature.

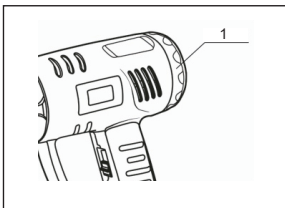

1.Temperature Adjusting Knob

### Upright Operation

Switch on the tool and wait for a minute until the

temperature attains the desired one before operation. For cooling of the heated tool or to have both hands free for working, the tool can be placed down in the upright position on the rear housing surface.

**CAUTION:** Be especially careful when working with the upright tool! There is danger of burning on the hot nozzle and the hot air stream.

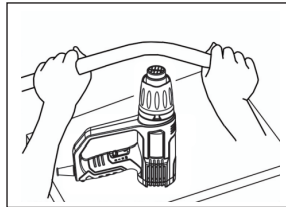

### • Removing Paint/Softening Adhesives

#### CAUTION:

- Keep the working area well ventilated when working indoors. Harmful poison gas may be produced when heating lead-base paint.

Place on the glass protection nozzle. Switch on the tool and adjust the temperature appropriately.

Point the nozzle to the surface of the paint to be removed and soften the paint using hot air and remove evenly using a spatula.

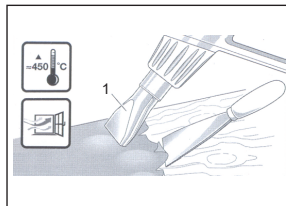

1.Glass Protection Nozzle

Do not heat the paint for too long since this will burn the paint, making it more difficult to remove. The spatula should be kept sharp and clean.

The spatula should be cleaned regularly. Remove

the scraped paint before it has hardened to prevent it from sticking to the cutting edge. Many adhesives (e.g. stickers) become softer when heated allowing adhesive bonds to be separated or superfluous adhesive to be removed.

Be sure that the material of the surface to be heated is non-flammable. Do not point the hot air stream at the frames of the window or at other surface of the glass.

### • Shaping Plastic Tubing

To avoid kinking the tubing, fill the tubing with sand and seal at both ends. Heat the tubing evenly by moving it from side to side.

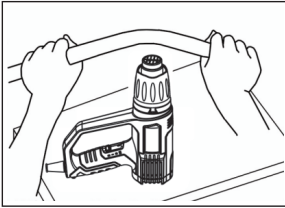

### • Shrink Fitting

Place on the reduction nozzle. Select the diameter of the heat-shrink tubing according to the workpiece, for example, a cable lug.

Heat the heat-shrinkable sleeve evenly.

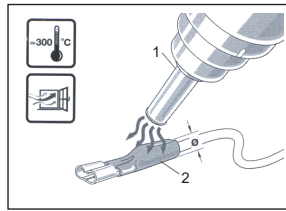

1.Reduction Nozzle  
2.Heat-shrinkable Tubing

### • Removing Paint from Window Frames

#### CAUTION:

- Danger of glass breaking!

Use of the glass protection nozzle (accessory).

On profiled surfaces, paint can be removed using spatula and brushed off using a soft wire brush.

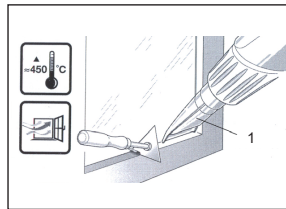

1.Glass Protection Nozzle

### Recommended Applicable Temperature

LOW	122-300 °F (50-150 °C)	Unfreeze the frozen pipe.
	400-450 °F (205-230 °C)	Shape plastic pipe or soften paint.
	450-550 °F (230-290 °C)	Soften adhesives.
	800-850 °F (425-455 °C)	Soften weldment.
	900-950 °F (480-510 °C)	Loosen rusted bolt.
HIGH	1000-1022 °F (520-550 °C)	Remove paint.
	1022 °F (550 °C)	Becomes coking.

### MAINTENANCE AND CLEANING

#### CAUTION:

**Always be sure that the tool is switched off and unplugged before attempting to perform inspection or maintenance.**

For safe and efficient working, always keep the machine and the ventilation slots clean. Do not clean the tool with rosinol, oil paint mixture, gasoline, or something like that.

## EXPLANATION OF GENERAL VIEW

1	Protective Cover	19	Cross Recessed Raised Countersunk Head Tapping Screw ST 3.5×10
2	Retaining Plate	20	Switch Slider
3	Heater Bushing	21	Switch
4	Heating Cord	22	Cross Recessed Pan Head Tapping Screw ST4.2×15
5	Insulating Paper	23	Strain Relief
6	Air Deflector Ring	24	Cross Recessed Pan Head Tapping Screw ST2.9×9
7	Cross Recessed Raised Countersunk Head Tapping Screw ST 3.5×10	26	Cross Recessed Pan Head Tapping Screw ST4.2×15
8	Rear Cover	28	Rubber Sleeve
9	Cord	T1	Motor Housing
11	Cord Guard	T2	Motor Fan Assembly
12	Small Terminal Block	T3	Switch Assembly
13	Circuit Board	T4	Flat Airduct
18	Cross Recessed Pan Head Tapping Screw With Washer ST2.9×15	T5	Round Airduct

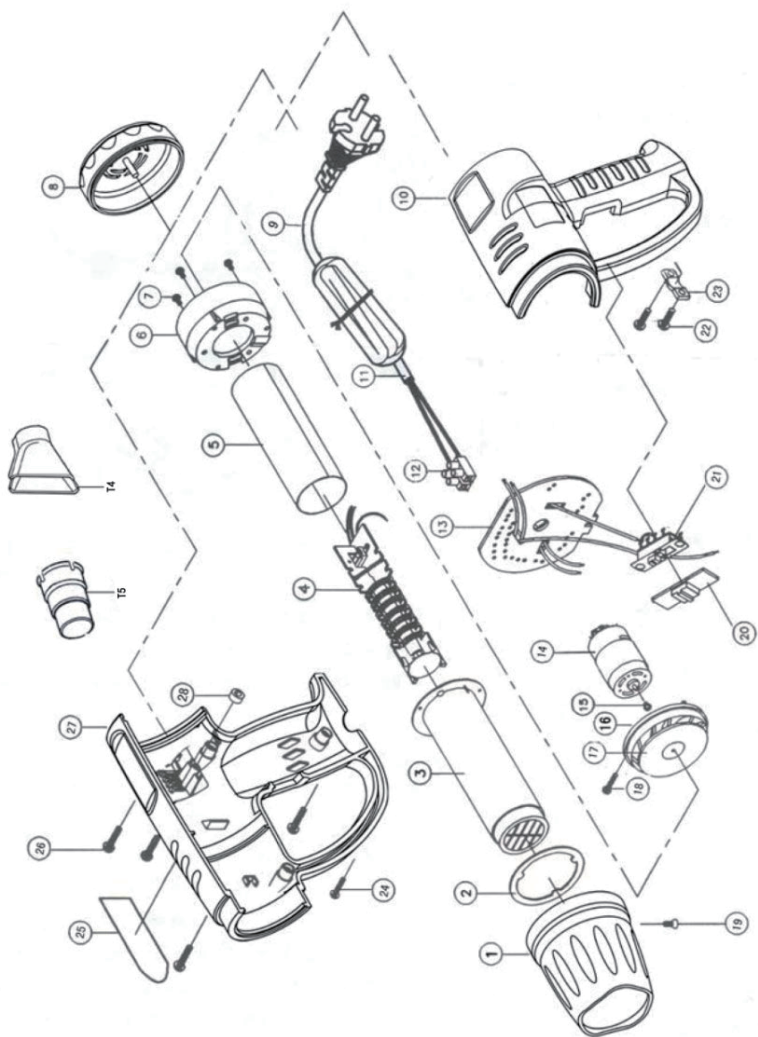

INNOVATION  
PERFORMANCE  
SAFETY  
CONFIDENCE  
GAZELLE

**GAZELLE**

[sales@gazelleindustrial.com](mailto:sales@gazelleindustrial.com) | [www.gazelleindustrial.com](http://www.gazelleindustrial.com)